



www.editada.org

## Personalized Education and Artificial Intelligence

Alejandro Fuentes Penna<sup>1</sup>, Juan de Dios González Ibarra<sup>1</sup>

<sup>1</sup> El Colegio de Morelos

alejandrofuentes@elcolegiodemorelos.edu.mx

**Abstract.** The Sustainable Development Goals (SDGs) are a universal call for action to end poverty, protect the planet, and improve people's quality of life. With the approval of the 17 SDGs as part of the 2030 Agenda for Sustainable Development, a plan was established to achieve them in 15 years.

Quality Education (SDG 4) is fundamental to developing people and societies, as it enables individuals to express themselves, actively participate in society, and make decisions that benefit their lives. Access to education is a determining factor in overcoming poverty and discrimination; it can improve the quality of life through an orientation towards better job opportunities, better health conditions, and greater participation in civic activities, among other aspects in which education has a direct or indirect impact. In this chapter, we present the importance of new technologies as facilitators to expand the positive influence of education.

Keywords: Sustainable development goals (SDGs), Education, Artificial Intelligence.

Article Info

Received Mar 20, 2024

Accepted May 11, 2024

## 1 Introduction

Education is a complex human and cultural process. To establish its definition and central objective, it is necessary to consider the condition and nature of man and culture as a whole, for which each particularity makes sense because of its linkage and interdependence with the others.

The human tends to learn alone, using, in principle, the context of his place of origin, his own culture, and, consequently, initiates his history. However, man needs to learn what is not innate to him to enhance what he has been given by genetic inheritance. For this reason, man needs others and culture to guarantee his transit through the world, being the foundation of the educational process.

Education has been a fundamental part of society since ancient times. Different cultures civilizations, and educational systems have been developed to transmit knowledge, values, and skills from generation to generation.

Education provides people with the knowledge and skills necessary to understand the world around them, develop as individuals, and reach their full potential. With the knowledge acquired, the skills, aptitudes, and competencies, among other relevant aspects of education, the make decision solutions are easier to understand.

Thus, education has been essential for the integral development of individuals and societies, being a fundamental human right and a key investment for the future.

### Goal 4. Ensure inclusive and equitable quality education and promote lifelong learning opportunities for all

The United Nations Sustainable Development Goal number 4 (SDG 4) focuses on ensuring inclusive and equitable quality education and promoting lifelong learning opportunities for all. This goal is part of the 2030 Agenda for Sustainable Development and highlights the importance of education as an essential component in addressing various challenges and promoting sustainable development.

SDG 4 seeks to ensure that all people have access to inclusive education, which involves removing barriers and providing educational opportunities for all, including marginalized and vulnerable groups. The present goal seeks to reduce disparity in access to education and improve equality of opportunity, however, this would involve addressing challenges such as gender discrimination, socioeconomic differences, and geographic barriers that may limit access to quality education.

In the SGD 4 proposal, it is not only a question of access, but also of the quality of education. This objective focuses on improving the quality of teaching and learning, ensuring that education systems provide relevant knowledge and skills for life and work in an ever-changing world. In doing so, it seeks to create opportunities for lifelong learning (continuing education). This encompasses formal education, vocational training, and non-formal education.

The global perspective of the GDS recognizes the importance of international cooperation in addressing global educational challenges and guiding collaboration among governments, international organizations, the private sector, and civil society to achieve significant progress toward this goal. The goals of SGD 4 are (UN, n. d.):

- Ensure access to free, equitable, and quality primary and secondary education for all children and produce relevant and effective learning outcomes.
- Ensure access to quality early childhood care and development services and quality preschool education
- Ensuring equal access to quality technical, vocational, and higher education, including university education for all people
- Increase the number of youth and adults with the skills (technical and professional) to access employment, decent work, and entrepreneurship.
- Eliminate gender disparities in education and ensure equal access to all levels of education and vocational training for vulnerable people, including people with disabilities, indigenous peoples, and children in vulnerable situations
- Ensure that young people and adults are literate and numerate
- Ensure the acquisition of theoretical-practical knowledge to promote sustainable development:
  - Expand educational facilities based on the needs of children and people with disabilities, and gender differences.
  - Increase the amount of scholarships for developing countries.
  - Increasing the supply of qualified teachers.

## **II Artificial Intelligence Applications to Education**

The use of technology in education has significantly transformed how teaching and learning occur. Among the most important benefits of technology is access to information, however, it is necessary to train students in the understanding of data and its proper use, mainly towards the development of technological skills. On the other hand, the technologies themselves are a complement to the teaching-learning process:

- Educational models mediated by technology,
- Innovative teaching methodologies,
- Personalized learning,
- Online interactivity education,
- Virtual learning environments,
- Flexibility in learning,
- Systematization of evaluation and feedback and
- In general, support for students in their preparation for the future.

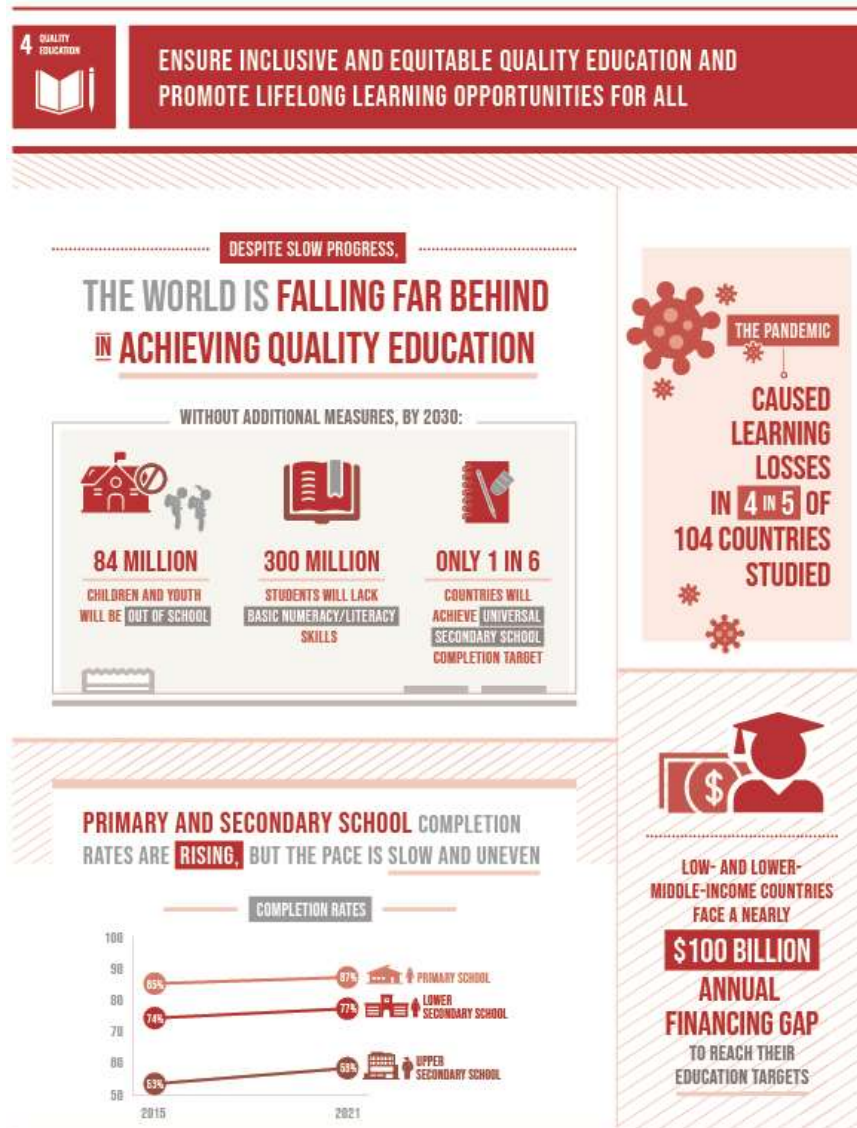

Fig. 1. Goal 4 – Quality Education (UN, s. f.).

Since the COVID-19 pandemic, different technologies have been implemented to facilitate access to knowledge. As the main technology, online learning was an option chosen to continue teaching through virtual support for students. As a complement, Artificial Intelligence has become the core of the several improvements that have been applied to technology-mediated education, identifying as alternatives:

- Virtual and augmented reality,
- Gamification,
- Educational robotics,
- Learning analytics,
- Cloud-based education,
- Virtual assistants and chatbots,
- Blockchain in education,
- Cloud-based education,
- Among other areas of new technologies that have benefited education itself.

Despite these benefits, it is important to address challenges such as the digital divide and ensure that technology is used ethically and equitably in the educational environment. Effective integration of these technologies into education requires careful planning and consideration of challenges such as the digital divide and data security. When used appropriately, these new technologies can significantly improve the quality and reach of education.

## 2.1 Personalize Education

Amid the information and knowledge society, there has been the possibility and opportunity to establish new challenges for education, where personalized education has the necessary tools to be applied in current contexts.

The proliferation of innovative experiences has bet on the use of technological tools that allow learning in individual environments, having as examples, MOOCs (massive open online courses), flipped classrooms, and personal learning environments, among others, that arise around the use of Information and Communication Technologies (ICT) and that try to take advantage of all their communicative, collaborative, interactive, and innovative, within the framework of a new learning culture (Adell and Castañeda, 2012).

The technological revolution of the 21st century applied to education has allowed educational models to be flexible and, therefore, lets the incorporation of personalized training elements through the use of digital resources that are present at all times.

Current educational models are oriented towards a teaching-learning process based on participation and collaboration. Students acquire competencies while interacting in virtual environments, working in teams using telematic media, and alternating virtual and face-to-face communication.

On the other hand, technologies are making it possible to attend to the singularity of each student, giving them a leading role that allows them to discover knowledge by themselves, decide the means they use to document themselves, and even self-evaluate their learning, resorting to technology throughout this process (Fundación Telefónica, 2012). The student choose his activities according to the tasks previously organized by the teacher, offering autonomy in his intellectual, social, and moral formation, being the active school on a didactic basis. Calderero Hernández et al. (2014), present Table 1 as a summary of theories around personalized education.

**Table 1.** Summary of theories around personalized education.

<i>Author</i>	<i>Period</i>	<i>Main contribution</i>
Claparède, Edouard	1873-1940	Claparède promotes the free choice of activities to enhance intellectual, social, and moral growth, and personality of the student's development.
Parkhurst, Helen	1886-1973	Parkhurst considers the student's learning as an individual process, respecting the child's activity.
Washburne, Carleton W.	1889-1968	Washburne is a pioneer in individualized teaching and personalized education. It introduces creative activities, group activities, and open forums, and values the emotional and social dimensions of the student.
Keller, Fred S.	1889-1996	Keller develops a Personalized Instruction System (SIP), each student advances at his or her own pace, supported by an advisory guide to clarify doubts, reinforce content, and provide guidance on study methods.
Faure, Pierre	1904 - 1988	Faure offers a vision of personalist pedagogy but at the same time communitarian, providing educational strategies
García Hoz, V.	1911-1998	García Hoz used the term Person and gave special relevance to the student's active role in his or her education and to cognitive and learning Styles. Promotes the use of educational technology and information technology.
Peters, R.S.	1919	Peters clarifies educational concepts and values educational thinking

Goodlad, John	1920	Goodlad describes education as a process in which freedom of thought and action must be developed.
Vázquez, Stella Maris	1945	Vázquez proposed the objectives for an educator: to be a guide to develop in the student his own personal, psychological, and moral knowledge, and to favor the development of his virtues to be incorporated into society.
Daura, Florencia Teresta	1979	Daura mentioned that university teachers have to use personalized teaching strategies, and students have to develop self-regulated learning.

The philosopher Plotino Domínguez (Ayala, 2006) indicates that each person is responsible for building his or her personality and ways of relating to others. However, people require interaction with the environment to complement what they do not know. With this, the author presents the 2 poles that make up the personal being: one's possibilities such as one's capabilities, virtues, and others.

Based on his possibilities, each person (the student) investigates, explores, is interested in finding out about what actively surrounds him and not only reacts to stimuli from the biological point of view but also to social stimuli, where personalized education plays an important role, since each student uniquely perceives his environment and with it, everything that is presented to him in the learning process.

Some theoretical and methodological keys of ICT to support the student's educational progress to undertake improvement actions can be found in González and Rodríguez (2010). The authors proposed theoretical and methodological keys on the use of technology to support student progress, closely linked to personalized education such as:

- Personal interests,
- Inclusion of collaborative groups,
- Emotions,
- Interaction,
- Continuous and contextualized learning,
- Among others.

Some examples of personalized education with the support of technology are the inverted classrooms proposed by Hamdan et al. (2013), and the personal learning environments (PLE) defined by Adell & Castañeda (2010) as a practice of people learning using technology.

Currently, there is a social need for hybridization between the face-to-face and the virtual, the physical and the digital, as a tendency to organize into social groups with common goals, a taste for personalized learning, experimentation, and ubiquity (Fundación Telefónica, 2012). This transformation demands flexible and versatile minds to adapt to changes for greater autonomy, where pedagogical renewal allows individuals to actively participate in their learning process, in a reflective education as proposed by García Hoz (1988), where the teacher is a mediator in the learning process to be carried out by the student himself to acquire an objective and own criterion, which makes him able to make informed, legitimate and effective decisions.

The new Internet services have opened to communication the ease and speed of dissemination of ideas, the breaking of geographical and temporal barriers, the democratization of knowledge, the personalization and experimentation of knowledge, the freedom of the Internet user in the opening to the world, the collaborative and flexible tools, ... are some reasons that make possible an education that forms integral beings, a personalized, convivial, inclusive, open, reflective, critical, demanding and joyful education (Castellanos, 2013).

## 2.2 Inclusive Education

Educational Inclusion is related to access, participation, and achievement of all students. UNESCO (2009) considers Inclusive Education as a key strategy to achieve Education for All (declaration approved in 1990), based on the fact that education is a

basic human right for a fairer and more egalitarian society. In this sense, the purpose of inclusive education is to enable teachers and students to feel comfortable with diversity and perceive it not as a problem, but as a challenge and an opportunity to enrich the teaching and learning process.

Echeita and Ainscow (2011) proposed four determinant elements of inclusion:

- Educational inclusion must be understood as a process of change that requires continuous revisions and progressive improvements, and cannot be reduced simply to a law or a specific discourse with a limited time frame,
- Inclusion seeks the presence, participation, and success of all students, students, and society as a whole,
- Inclusion requires the identification and elimination of barriers, and
- Inclusion pays special attention to those students at risk of being marginalized, excluded, or at risk of not achieving optimal performance.
- Inclusive Education should be conceived as a process that allows addressing and responding to the diversity of needs of all students, students, and the educational community itself, through greater participation in learning and reduction of exclusion from the educational system.

This implies changes and modifications of contents, approaches, structures, and strategies based on a common vision and the conviction that it is the responsibility of the Educational System to educate all students, students and the educational community itself, through greater participation in learning and reduction of exclusion from the educational system.

These are three questions related to inclusive education: a) how do we understand it, b) what do we do to achieve it, and c) how can we continue to improve our practices and inclusive professional communities to build, develop and consolidate, among all of us, a true educational system that places the primordial right to diversity as a central axis of change in educational centers.

Booth and Ainscow (2002) identify that inclusive education requires three dimensions (figure 2):

- Creating inclusive cultures
- Developing inclusive policies
- Developing inclusive practices



**Fig. 2.** Dimensions for inclusive education.

The relationship between culture, policy, and practice is not linear or hierarchical, but circular and partly diffuse – imprecise, and requires:

- Establishment of inclusive professional communities: create working groups of all members of the educational community: families, students, teaching staff, management team, administration and services staff, and others from the community like volunteers, people belonging to non-profit associations or non-governmental organizations, trainees from university degrees or vocational training related to education, etc.
- Teaching-learning methodologies based on cooperative learning and work. It requires the formation of heterogeneous work groups, where students with disabilities, specific learning difficulties, high intellectual abilities, chronic diseases, immigrant population, developmental disorders, etc., are working as part of these groups together with the rest of their classmates.
- Didactic resources and means of expression that comply with the principles of the "Universal Design for Learning", since each person has a specific learning style.

Technology, especially artificial intelligence (AI), plays a key role in promoting inclusive education by providing tools and resources that can be tailored to the individual needs of students with diverse skills and abilities.

Technology and AI enable the creation of personalized learning environments that are tailored to the specific needs of each student. This is crucial to ensure that all students, regardless of their differences, can receive an education tailored to their learning pace, learning style, and ability level.

These tools can generate online learning platforms, educational applications, and digital resources that provide universal access to education. This is especially beneficial for students with disabilities or those in remote areas, where access to traditional education may be limited.

Moreover, AI can provide real-time support and assistance to learners as they engage in learning activities. This includes instant feedback, personalized tutoring, and suggestions for addressing areas of difficulty. This assistance is invaluable for students with special needs, as it allows them to receive additional help without the need for the constant presence of a human instructor. Technology and AI can develop accessibility tools, such as screen readers, text-to-speech translation, automatic captioning, and augmentative and alternative communication devices, that make educational content accessible to students with visual, hearing, or communication disabilities.

AI systems can analyze large amounts of data to identify patterns and trends that could indicate the need for early intervention for students with special needs. In addition, these technologies can track student progress over time and adapt educational strategies as needed.

In conclusion, technology and artificial intelligence are essential for creating inclusive educational environments where all students have the opportunity to reach their full potential, regardless of their differences. These tools offer personalization, accessibility, and support, which contributes significantly to equitable and quality education for all.

### **2.3 Educational Robotics**

Educational robotics is an area of Artificial Intelligence that uses robots as pedagogical tools to facilitate the learning and teaching of various concepts, especially in areas related to science, technology, engineering, and mathematics (STEM). Figure 3 presents the main advantages of educational robotics.

Table 1 shows examples of patents obtained in the international search engine (WIPO, 2024) of the World Intellectual Property Organization (WIPO) related to the use of educational robotics.

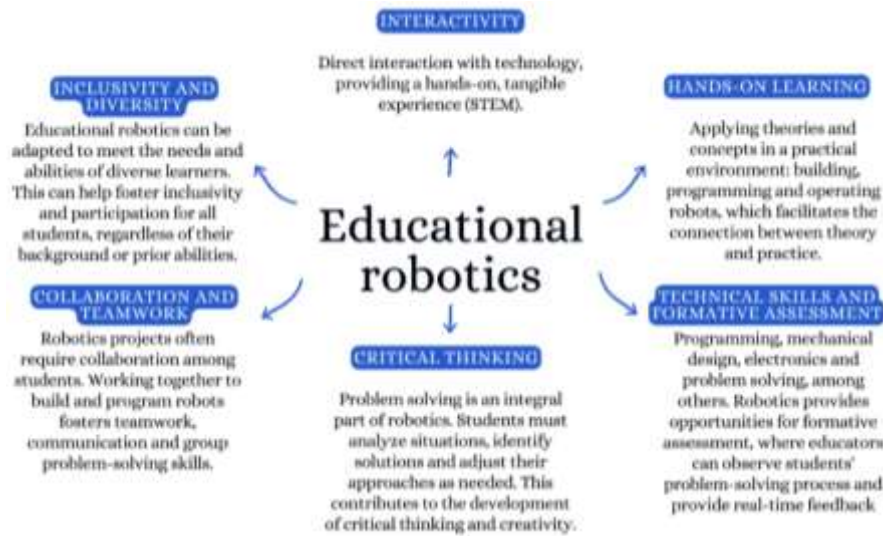

**Fig. 3.** Educational robotics.

**Table 2** Examples of educational robotics patents (WIPO, 2024).

Title	Authors	Description
Artificial intelligence education method and device	Xie Xilin & Li Bensong	The method collects educational knowledge information and learning information from students, processes this information to obtain a standard value and an acquisition value of learning information; and processes the data analysis information to generate different educational signals and provide educational guidance for each student. The method employs an artificial intelligence-based educational device.
Artificial intelligence education robot	Chuai Liwei, Zheng Dongxu & Shi Jingya	The artificial intelligence educational robot interacts with students through intelligent voice commands and includes educational curriculum resources based on entertainment interaction, voice chat, video call interaction, and interface operation.
Artificial intelligence education robot (Figure 4)	Zhang Mujie & Sun Licheng	The description presents information about the parts that make up the robot but does not describe the functionality of the robot.
Interactive Artificial Intelligence Controlled Education System	Celenk Ulas	The proposal is oriented to provide education equipped with a microphone, camera, and speaker that allows the performance of cartoon characters according to the scenarios provided to them depending on the detection of speech and movement of children with artificial intelligence as a support for children with autism, attention deficit, hyperactivity disorder, developmental delay or psychological and neurological problems that require special support for normal development.
Artificial Intelligence K12 Education Full-Automatic Question Generation System. Multifunctional education robot	Fan Xing, Chang Zuxin & Ma Yi	This is a proposal for an automated question generation system for K12 education based on artificial intelligence, which can automatically set questions, ensure that these questions are unique, and generate problems for analysis.
	Zhong Zhigang, Lu Xizhen, Wu Dazhi,	The multi-functional educational robot consists of a multi-functional module with multiple sensors, students



(Figure 5)	Weng Jiejun, Wei Minghao, Deng Caimei, Fang Jicheng, Wen Shuhuai & Huang Peishan.	can learn from programs embedded in the educational robot. The robot is provided with pulleys controlled by a motor, two arms controlled by a second motor, and with the possibility of programming.
Interaction equipment of intelligent education robot (Figure 6)	Zhang Lipei	The intelligent robot features interactive equipment with structural stability for use in education.
Programmable education robot system	Liao Nan, Zhu Wenyou & Yang Jun	A programmable education robot system is presented. The robot contains a power supply management module, a main controller module, a wireless communication module, a sensor control module, a module for controlling a mechanical arm, a vehicle motion control module, a voice playback module, a programmatic interface module, a buzzer, and an indicator light. The robot system provides a graphical programming environment based on C programming language and assembler.
Intelligent education robot	Wu Hengli	The particularity of the intelligent education robot is a spherical housing and a base with a weight block. The robot is used for human-machine interaction and education of children. The robot has smart terminals for connecting smartphones so that network resources can be shared for learning various subjects such as English.
Family education robot (Figure 7)	Lin Jianling	The family education robot consists of a shell, an articulated arm connected to the intelligent processing system (driving device and control device), and a second articulated arm equipped with a laser pen for teaching.
Multi-foot education robot	Han Qingjiang	A multi-legged educational robot is presented, which consists of the upper part integrated by the robot body, its head and arms without movement, and the lower part mounted on a rotating base. One of its main features is the position of the battery for quick replacement.

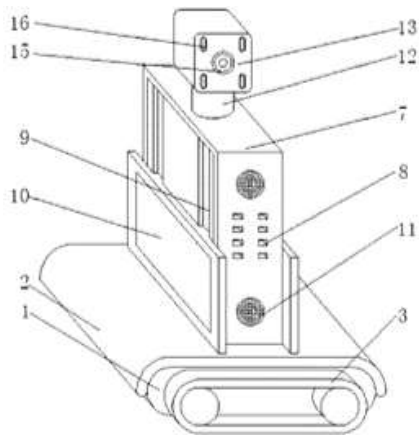
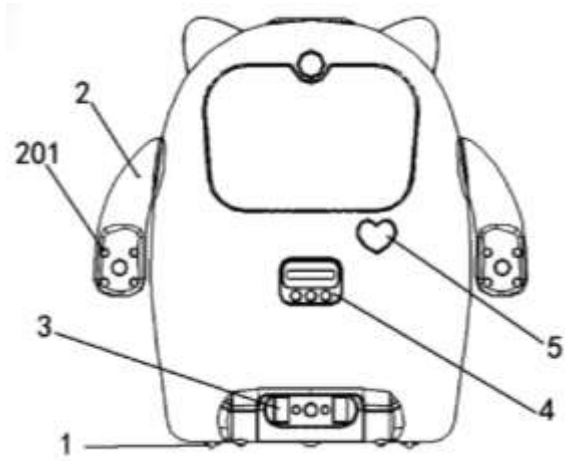
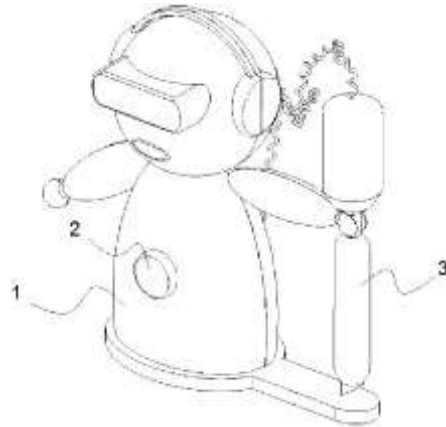

Fig 4. CN113021371 - Artificial intelligence education robot (Zhang Mujie & Sun Licheng, 2021).



**Fig. 5.** CN210189807 - Multifunctional Education Robot (Zhong Zhigang et al., 2020).



**Fig. 6.** CN219267121 - Interaction Equipment of Intelligent Education Robot (Zhang Lipei, 2022).

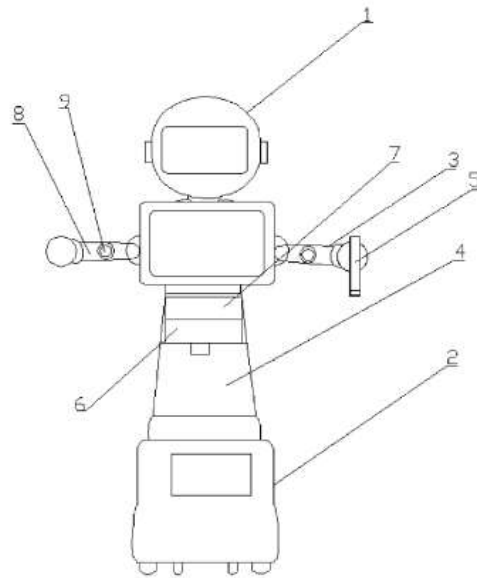

**Fig. 7.** CN105869460 - Family Education Robot (Lin Jianling, 2016).

### III Ethics and Privacy in AI-Assisted Education

Ethics and privacy are critical issues to consider in the development and implementation of AI-based assisted learning systems. AI-based systems used in education must be transparent about their functionality and decision-making. Algorithms must be explainable so that students, educators, and decision-makers understand how the data are used and how the results are generated. In turn, it is crucial to ensure that systems do not have biases in the data or the design of the algorithm-based solution, so measures must be implemented to identify and mitigate potential algorithmic biases that could affect certain groups of students.

The collection, storage, and use of data in AI-assisted education systems must comply with strict privacy standards. It must be ensured that informed consent is obtained from students and/or their legal guardians before any personal information is collected. In addition, data must be securely protected to prevent any risk of unauthorized access or disclosure. These systems must implement robust security measures to protect data against potential cyber-attacks or security breaches through data encryption, user authentication, and constant monitoring for potential threats.

With this, developers and providers of AI-based educational technology are responsible for ensuring that their systems meet ethical and legal standards, systems must be transparent about the limitations and potential risks of their products, and be prepared to take responsibility should problems arise.

It is important to involve all stakeholders, including students, educators, parents, and ethics and privacy experts, in the design, implementation, and evaluation of AI-assisted education systems. This ensures that a variety of perspectives are considered and ethical and privacy concerns are adequately addressed. In summary, ethics and privacy are critical considerations in AI-assisted education, and addressing them proactively and transparently is essential to ensure that these systems are used responsibly and in a manner that is beneficial to all involved.

### 4 Conclusions

Ethics plays a fundamental role in the application of artificial intelligence (AI) in inclusive education. Equity is a crucial issue surrounding the use of AI to ensure that education reduces existing inequalities. The design of new elements related to education must take a holistic approach so that it benefits all students, regardless of their socioeconomic background, gender, ethnicity, abilities, or disabilities.

Algorithms used in education should be transparent and oriented so that all stakeholders, such as students, teachers, and decision-makers, and in general, anyone who wants to learn, can use AI as part of their educational experiences.

However, the collection and use of data by AI systems must comply with privacy laws and regulations. Measures must be put in place to protect students' privacy and ensure that their data is not misused. Part of this responsibility is the generation of the data sets used to train AI models, which must be diverse and representative of the student population without bias and ensure that the systems work fairly for all students.

AI in education should be used to improve the teaching-learning process, where students promote their autonomy and allow them to learn at their own pace, adapting to their individual needs and encouraging active participation in their process.

Finally, SDG 4 seeks not only to ensure access to education, but also to improve its quality, promote inclusiveness and equity, and recognize the importance of lifelong learning opportunities to achieve sustainable development at the global level.

### References

- Baldonado, M., Chang, C.-C.K., Gravano, L., Paepcke, A.: The Stanford Digital Library Metadata Architecture. *Int. J. Digit. Libr.* 1 (1997) 108–122
- Bruce, K.B., Cardelli, L., Pierce, B.C.: Comparing Object Encodings. In: Abadi, M., Ito, T. (eds.): *Theoretical Aspects of Computer Software. Lecture Notes in Computer Science*, Vol. 1281. Springer-Verlag, Berlin Heidelberg New York (1997) 415–438
- Van Leeuwen, J. (ed.): *Computer Science Today. Recent Trends and Developments. Lecture Notes in Computer Science*, Vol. 1000. Springer-Verlag, Berlin Heidelberg New York (1995)
- Michalewicz, Z.: *Genetic Algorithms + Data Structures = Evolution Programs*. 3rd ed. Springer-Verlag, Berlin Heidelberg New York (1996)

Smith, T.F., Waterman, M.S.: Identification of Common Molecular Subsequences. *J. Mol. Biol.* 147, 195--197 (1981). doi:10-312/102938764

May, P., Ehrlich, H.C., Steinke, T.: ZIB Structure Prediction Pipeline: Composing a Complex Biological Workflow through Web Services. In: Nagel, W.E., Walter, W.V., Lehner, W. (eds.) *Euro-Par 2006. LNCS*, vol. 4128, pp. 1148--1158. Springer, Heidelberg (2006)

Foster, I., Kesselman, C.: *The Grid: Blueprint for a New Computing Infrastructure*. Morgan Kaufmann, San Francisco (1999)

Czajkowski, K., Fitzgerald, S., Foster, I., Kesselman, C.: Grid Information Services for Distributed Resource Sharing. In: 10th IEEE International Symposium on High-Performance Distributed Computing, pp. 181--184. IEEE Press, New York (2001)

Foster, I., Kesselman, C., Nick, J., Tuecke, S.: *The Physiology of the Grid: an Open Grid Services Architecture for Distributed Systems Integration*. Technical report, Global Grid Forum (2002)

National Center for Biotechnology Information, <http://www.ncbi.nlm.nih.gov>