



www.editada.org

## Embedded system based on IoT and V2X for Smart Cities

*Israel Campero-Jurado, Juan Quintanar-Gómez, Oscar Daniel Vargas-Buitrón, Francisco R. Trejo-Macotela, Daniel Robles-Camarillo, Eric Simancas-Acevedo.*

<sup>1</sup> Posgrado en Tecnologías de Información y Comunicaciones, Universidad Politécnica de Pachuca  
*juanquintanargomez@micorreo.upp.edu.mx*

**Abstract.** Today, the entire environment that shapes our society is being modernized. Advances in technology allow us to materialize ideas that previously seemed impossible, from controlling a house to digitizing entire cities. This article proposes the design of an embedded system using V2X (Vehicle to Everything) communication. This electronic system is connected to smart devices to optimize vehicle flow in high conglomeration cities. This system communicates through IIoT (Internet of Industrial Things), allowing real-time information reception, in order to make decisions. This work is directed towards the alternative of intelligent cities, industry 4.0, and artificial intelligence techniques to improve the quality of life of people inhabiting a certain zone.

**Keywords:** Artificial Intelligence, Smart Cities, IoT, IoIT, V2X, V2D, V2I, V2P, V2V, Industry 4.0

Article Info

*Received Feb 26, 2019*

*Accepted Mar 12, 2019*

## 1 Introduction

Smart cities' objective is to improve mobility, efficiency, security and public services, and they are closely related to technologic tools and their usage. Smart cities are meant for citizens, that is why they bet for competitiveness in different areas, with benefits in different aspects, such as economics and quality of life of their inhabitants. In other words, they focus on wealthiness generation, not only tangible but intangible, maintaining collaboration between technology and society. Thanks to this, it is possible to talk about V2X, which has primordial objectives, such as guaranteeing the security of its environment and of itself, expanding its versatility for different use cases, analysing data provided by the car. This has to do with the concept of Smart Cities, which are made to improve their inhabitants' living conditions. V2X has the easiness to provide efficient protocols to control autonomous vehicles. Because of this, it is called Vehicle to Everything. Together with Industry 4.0, these are revolutionary areas with the objective of digitizing the world through a universal connection.

This article introduces design and modelling of an electronic system specialized in communication between vehicles and devices (V2D), for its implementation in a smart city real environment, obtaining information from its environment in real-time, in order to make decisions, lowering issues related to traffic density, and diminishing car accidents as well. Generated data will be analysed through artificial intelligence techniques, allowing to learn from the environment in which cars perform.

## 2 State of the art

Almeida et al. [1] propose communication between different devices that get and process information from their environment through a low power wide area network (LPWAN), LoRa network, providing connectivity and energy saving, as current devices' main problem is their low energy performance, for energy is spent finding a receptor to transmit information to the Internet.

Hobert et al. [2] present an analysis of smartphones usage, implemented in communication with autonomous vehicles through V2X protocol, analysing aspects to be implemented to achieve a better link between devices and autonomous vehicles.

Naranjo et al. [3] propose a connection between vehicles and infrastructures through V2X protocol, with the objective of notifying drivers or pedestrians through signs from infrastructures or vehicle notifications, when a motorcycle or any kind of 2-wheeled vehicles are added to their environment.

Nardini et al. [4] analyse the utility of the Vehicle to Cell phone (V2C) protocol, using 3GPP protocol through a new algorithm that improves its information transmission efficiency, and device hardware and software managing.

Rainer and Petscharnig [5] analyse essential features of an information-centric network (ICN), used in V2X protocols interconnection, to strengthen security breaches during information transmission by network structures, providing security to human resources in the environment where devices connected to a network are being used.

Iqbal and Khan [6] propose an algorithm used in opportune detection of issues caused by vehicle-smart cities interaction, as well as the analysis of other external factors that provoke a bad determination of traffic density, providing a fast response to any alteration that affects traffic flow in smart cities.

Lee et al. [7] implement an algorithm in charge of the analysis of different routes to a destiny, besides identifying through simulations routes that propitiate lower traffic flow when there is an incident in the analysed route, obtaining a route that eases traffic flow and commute time.

Li et al. [8] propose the implementation of a genetic algorithm (GA), complemented with a particle swarm optimization (PSO) algorithm to analyse traffic density in highways, with the objective of lowering energy consumption within most traffic density areas through a dynamic speed limit in certain areas, generating a conscious, pedestrian-friendly driving style.

Liu et al. [9] propose communication between vehicles, managing their speed and environment perception in real-time, in order to diminish accident rates on intersections where there is no infrastructure to guarantee traffic flow. This guarantees vehicle and passenger integrity.

Sun et al. [10] propose cooperative driving between the driver and smart system, notifying driver of any inconvenient in the route to their destiny, in order to optimize commute time and diminishing vehicle's energy consumption.

Sanguesa et al. [11] propose the combination of vehicle-to-vehicle communication protocols (V2V) and vehicle to infrastructure (V2I), improving quality of data, propitiating a better environment understanding for devices, and reducing mistakes generated during decision making when using a specific environment protocol.

Protzmann et al. [12] analyse propagation models configurations, used in V2X communication through simulations of information transmission between vehicles, in order to select models with the least latency during messages transmission within a certain environment.

Hirai and Murase [13] propose the implementation of a data cluster to transmit information from collision warning systems to any close node within the environment, increasing real-time data transmission efficiency, reducing the probability of wrong data being transmitted.

Olaverri-Monreal et al. [14] implement a traffic simulator by linking V2X communication technologies with the driver, generating a learning process between driver and vehicle's smart system in order to improve vehicle's environment perspective to make optimal real-time decisions.

Jeon, Kuk and Kim [15] propose to use a communications algorithm to reduce collision rates generated by third devices broadcasting information, optimizing energy consumption required to send information to close nodes.

Ahn, Kim and Kim [16] propose a model that uses IEEE 802.11p protocols, diminishing the breach between vehicles that use current and old communication channels, by using protocol compatibility within transmission channels.

Wei et al. [17] analyse and evaluate existing communication between smart vehicles and smartphones, in order to manage energy consumption during information transmission between both devices, guaranteeing energy savings and security during information exchange.

Siegel, Erb and Sarma [18] details the impact of emerging technologies in information transmission from vehicles to their environment, aspects that benefit society by obtaining information from the vehicle and areas where these technologies have been implemented around the world.

Qi et al. [19] compare energy-saving propitiated by a smart driving model against traditional driving, showing a better performance by the smart driving model.

Jin et al. [20] show different aspects between traditional driving and autonomous vehicles with a feedback algorithm, pointing a passengers' security increment, and energy savings that propitiate a better quality of life for passengers and the environment around the vehicle.

Bazzi et al. [21] propose smart vehicles data transmission through bidirectional communication channels that use collision detection protocols, focused on vehicular networks.

Bian, Zhang and Song [22] analyses existing security breaches within V2X communication networks, and informs about measures focused on correcting these issues, in order to guarantee communication channel security and energy saving.

Gao et al. [23] considers the distribution of information from infrastructure to groups of vehicles passing by it, plus transmitting information received by the vehicle to others, optimizing data traffic generated by infrastructure.

Martínez de Aragón, Alonso-Zarate and Laya [24] assembles a technical-business approach about the introduction of wireless communication between vehicles and how this affects the automotive sector. Also provide complementary information about how business opportunities may affect available wireless technology elections, as well as different perspectives about how the automotive sector is being evolved.

Noor-A-Rahim et al. [25] analyse and provide solutions to improve the performance of DSRC security messages broadcasting in an intersection, while protocol IEEE 802.11p is considered.

### 3 System overview

The developed system consists of the following elements, each one of them being classified y categories:

#### Connectivity

- Sigfox , observe the way information about this enterprise is being sent in Figure 1:

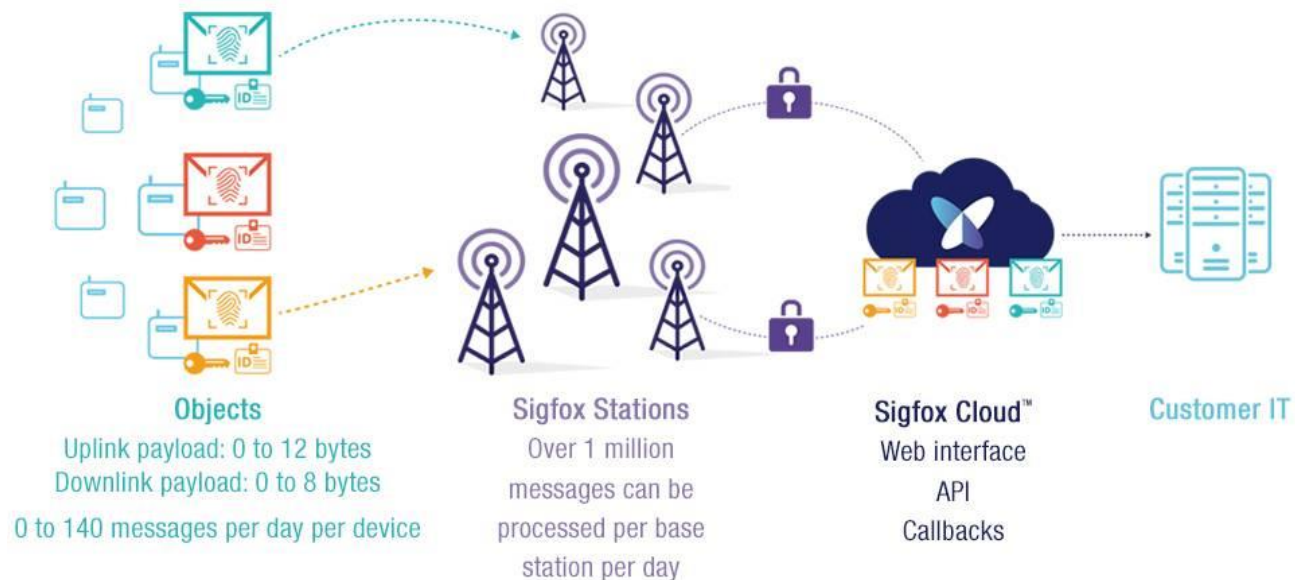

Figure 1. Sigfox, French enterprise dedicated to providing a low power wide area network, <https://sigfox.com>

Sigfox is a French enterprise founded in 2009, with a mission to provide a wide area network service with low power, known as LPWAN. Currently, Sigfox is developing amongst the world. Opting for Industry 4.0, a remarkable feature is its utility for sensors running with batteries, where frames are 12 bytes sized. Sigfox has bet for the Internet of Things (IoT).

Sigfox has important features, for which it was elected for its implementation in an electronic system capable of communicating through autonomous vehicles to devices within smart cities:

- Ultra-narrow band radio modulation: Using Ultra-narrow band radio modulation (UNB), Sigfox network can operate within 200 kHz of the band available for the public to use air as radiofrequency-based messages transference channel. Each one of the transmitted messages is 100 Hz width, and can be sent to a velocity of 100-600 b/s; however, this has restrictions depending on the region. It provides an error range high to prevent noise from affecting sent information.
- Light protocol: SigFox designed its protocol in case of getting information that does not require its entire performance, i. e. short messages. This has direct repercussions in the battery, for this means less energy consumption, resulting in an extended lifetime.
- Small useful load: Currently, SigFox manages messages up to 12 bytes long, taking 2 seconds to be delivered to their destiny. For downloading messages, the limit for useful load is 8 bytes.
- Star architecture: A SigFox device is never connected to a static base station, unlike telephony protocols, that are linked to the nearest base station (only one). SigFox messages are transmitted to any of the nearest base stations (the average is 3).
- Options and design advantages: SigFox chose to design their technology and network to satisfy current connection demand. Thanks to this there is a long lifetime for the connected device battery.

### Hardware

- Breakout Sigfox Wisol RCZ2, see Figure 2:

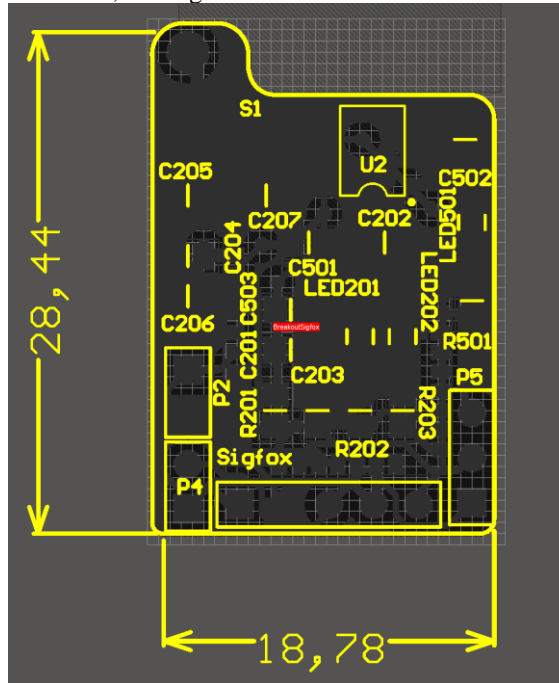

Figure 2. Sigfox Wisol RCZ2 Module (Image acquired directly from the manufacturer), <https://partners.sigfox.com/products/>

This module belongs to the SFM60 series, which is a dual module. It is integrated into BLE based engines, GPS compatible with SigFox LPWAN, as well as accelerometers for their application by the user. Each module component acts as an independent module and the main host ARM@Cortex M4 controls each module through an integrated API UN an only simple, easy-to-use SDK. It is also pin-to-pin with WSSFM20R Technology series.

- Wssfm10r2 sigfox module: The SFM10R2 SigFox Only mode is a miniaturized module for the Americas. This module has an integrated MCU, as well as an RF integrated transceiver, and it is compatible with UART for external communication.

TCXO is used in the module to maintain frequency tolerance for operative bands throughout the entire product's life.

- Microcontroller PIC 16F877A: functions for each of its 40 pins are detailed in Figure 3.

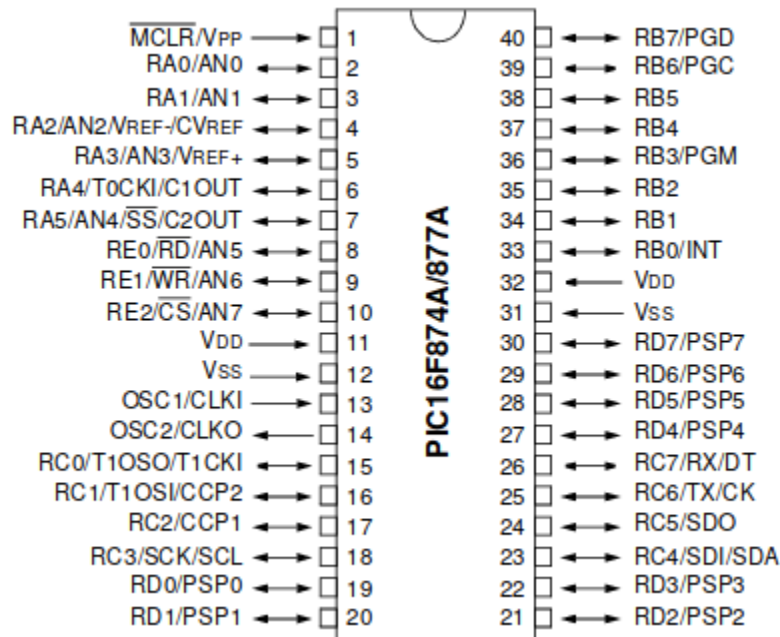

Figure 3. PIC 16F877A Data Sheet pins, <http://ww1.microchip.com>

This is an 8-bit microcontroller, which is founded in FLOS of CMOS. It acquires PIC architecture from Microchip in a 40 or 44 pin package, plus having wide compatibility with diverse development systems. The PIC16F877A has a 256-byte EEPROM (Electrically Erasable and Programmable ROM) memory, auto-programming, two comparators, eight 10-bit A/D channels, two capture functions, comparison, PWM, asynchronous serial port that can be configured as a 3-thread Serial Peripheral Interface and a Universal Synchronous-Asynchronous Receiver-Transmitter (USART).

Since it is a versatile microcontroller, it is used in different science areas. In this project, it will be used to communicate devices with autonomous vehicles in order to implement the system in a real environment.

#### 4 Methodology

This work has the objective of developing an electronic device capable of carrying out a Vehicle to Device (V2D) connection. This adds other concepts to the equation (see Figure 4).

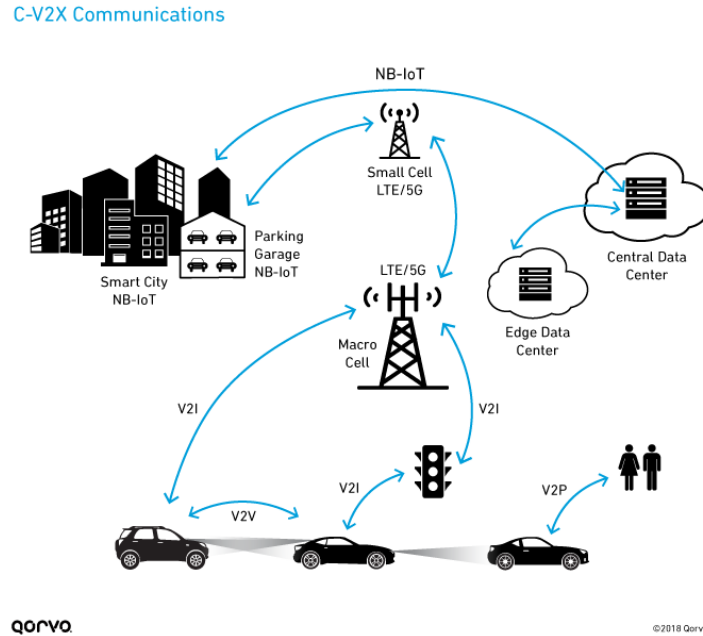

Figure 4. Smart Cities and V2X, <https://www.qorvo.com/design-hub/>

Prototypes methodology was used under the following steps:

1. Requisites gathering and refinement.
2. Quick design, communication system for V2D.
3. Prototype construction with SigFox module.
4. Prototype evaluation with a vehicle.
5. Prototype refinement, evaluation of IoT communication.
6. Engineering product.

Electronic system design and modelling process can be seen in Figure 5.

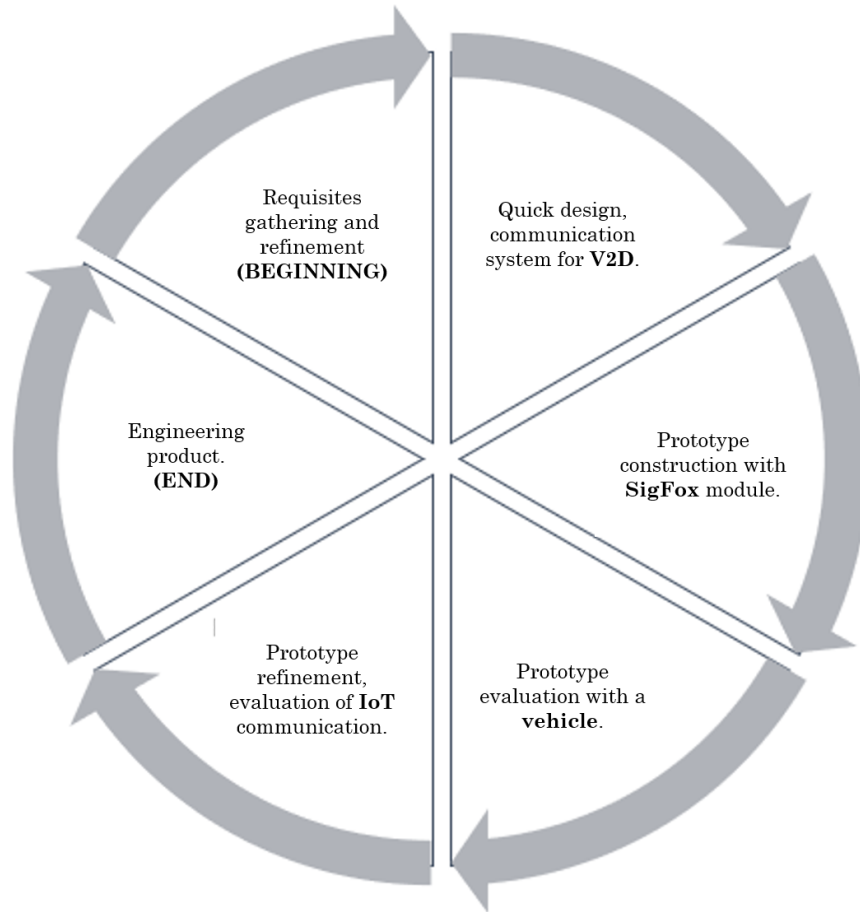

Figure 5. Prototype methodology, V2D communication system for smart cities.

## 5 System configuration

The module provided by SigFox has a configuration specialized in 12-byte messages, its connection structure can be seen in Figure 6, where initial parameters are established for its configuration with the microcontroller. This microcontroller was selected due to its 256-byte EEPROM memory (robust when processing information).

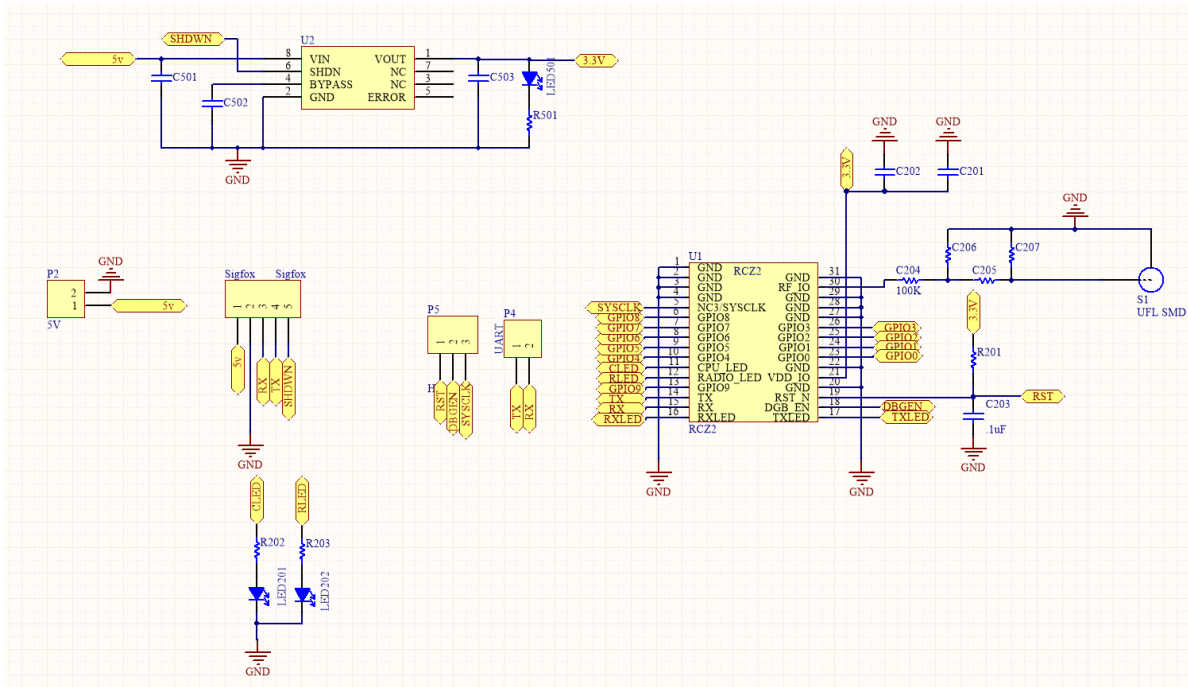

Figure 6. SigFox RCZ2 module initial setup for IoT (Image acquired directly from the manufacturer), <https://partners.sigfox.com/products/>

Assimilating the structure of the RCZ2 module, the PIC16F877A sets inputs and outputs. Output is set on pin RC7 to TXD on IoT module, as well as pin RC8 to RXD.

## 6 Conclusion

Smart cities have modified our perception of our environment. Thanks to facilities they provide to their inhabitants, quality of life have been improved in several aspects. In this document, information transmission between vehicles is being pointed. Components are being added to identify any aspect that surrounds them, as well as communication devices to provide information transmission and reception from devices near the vehicle. This way, the vehicle is given intelligence, and drivers and pedestrians are provided with a wide range of opportunities.

This is all possible thanks to the implementation of vehicular communication protocols, i.e., Vehicle to Everything. This provides real-time communication between vehicles, infrastructures and pedestrians, in order to prevent economic losses or, in the worst scenario, human casualties.

Several manufacturers have taken advantage of emerging technologies, such as the Internet of Things, Artificial Intelligence and Industry 4.0, to provide innovative ideas of vehicle usage. By using algorithms and electronic components, new applications have been generated to improve vehicles and driving experience, e. g., reduction of commute time by using apps that notify in real-time traffic density in a determined area. Such applications also help to reduce vehicle's energy consumption, leading to money savings and reduction of toxic gases in the area.

## References

1. Almeida, R., Oliveira, R., Lués, M., Senna, C. and Sargento, S. (2018). A Multi-Technology Communication Platform for Urban Mobile Sensing. *Sensors*, 18(4), 1184.
2. Hobert, L., Festag, A., Llatser, I., Altomare, L., Visintainer, F. & Kovacs, A. (2015). Enhancements of V2X communication in support of cooperative autonomous driving. *IEEE communications magazine*, 53(12), 64-70.
3. Naranjo, J. E., Jiménez, F., Anaya, J. J., Talavera, E. & Gómez, O. (2017). Application of vehicle to another entity (V2X) communications for motorcycle crash avoidance. *Journal of Intelligent Transportation Systems*, 21(4), 285-295.4



4. Nardini, G., Virdis, A., Campolo, C., Molinaro, A. & Stea, G. (2018). Cellular-V2X Communications for Platooning: Design and Evaluation. *Sensors*, 18(5), 1527-5
5. Rainer, B. & Petscharnig, S. (2018). Challenges and Opportunities of Named Data Networking in Vehicle-ToEverything Communication: A Review. *Information*, 9(11), 264.
6. Iqbal, Z. & Khan, M. I. (2018). Automatic incident detection in smart city using multiple traffic flow parameters via V2X communication. *International Journal of Distributed Sensor Networks*, 14(11), 1550147718815845.
7. Lee, S., Heydecker, B. G., Kim, J. & Park, S. (2017). Stability analysis on a dynamical model of route choice in a connected vehicle environment. *Transportation Research Procedia*, 23, 720-737.
8. Li, M., Wu, X., He, X., Yu, G. & Wang, Y. (2018). An eco-driving system for electric vehicles with signal control under V2X environment. *Transportation Research Part C: Emerging Technologies*, 93, 335-350.
9. Liu, B., Shi, Q., Song, Z. & El Kamel, A. (2019). Trajectory planning for autonomous intersection management of connected vehicles. *Simulation Modelling Practice and Theory*, 90, 16-30.
10. Sun, D., He, Y., Zhao, M. & Cheng, S. (2018). Cooperative driving modelling in the vicinity of traffic signals based on intelligent driver model. *IET Intelligent Transport Systems*, 12(10), 1236-1242.
11. Sanguesa, J. A., Barrachina, J., Fogue, M., Garrido, P., Martinez, F. J., Cano, J.-C., Calafate, C.T., Manzoni, P. (2015). Sensing traffic density combining V2V and V2I wireless communications. *Sensors*, 15(12), 31794-31810.
12. Protzmann, R., Schu, B., Radosch, I. y col. (2010). The influences of communication models on the simulated effectiveness of V2X applications. En *Vehicular Networking Conference (VNC), 2010 IEEE* (pp. 102-109). IEEE.
13. Hirai, T. & Murase, T. (2018). Node-clustering communication method to improve QoS in V2X communications in crash warning applications. *IEICE Communications Express*, 7(10), 376-381.
14. Olaverri-Monreal, C., Errea-Moreno, J., Dí'ez-Alvarez, A., Biurrun-Quel, C., Serrano-Arriezu, L. & Kuba, M. (2018). Connection of the SUMO Microscopic Traffic Simulator and the Unity 3D Game Engine to Evaluate V2X Communication-Based Systems. *Sensors*, 18(12), 4399.
15. Jeon, Y., Kuk, S. & Kim, H. (2018). Reducing Message Collisions in Sensing-Based Semi-Persistent Scheduling (SPS) by Using Reselection Lookaheads in Cellular V2X. *Sensors*, 18(12), 4388.
16. Ahn, J., Kim, Y. & Kim, R. (2018). A Novel WLAN Vehicle-To-Anything (V2X) Channel Access Scheme for IEEE 802.11 p-Based Next-Generation Connected Car Networks. *Applied Sciences*, 8(11), 2112.
17. Wei, Q., Wang, L., Feng, Z. & Ding, Z. (2018). Wireless resource management in LTE-U driven heterogeneous V2X communication networks. *IEEE Transactions on Vehicular Technology*, 67(8), 7508-7522.
18. Siegel, J. E., Erb, D. C. & Sarma, S. E. (2018). A Survey of the Connected Vehicle Landscape Architectures, Enabling Technologies, Applications, and Development Areas. *IEEE Transactions on Intelligent Transportation Systems*, 19(8), 2391-2406.
19. Qi, X., Wang, P., Wu, G., Boriboonsomsin, K. & Barth, M. J. (2018). Connected Cooperative Ecodriving System Considering Human Driver Error. *IEEE Transactions on Intelligent Transportation Systems*, 19(8), 2721-2733.
20. Jin, I. G., Avedisov, S. S., He, C. R., Qin, W. B., Sadeghpour, M. & Orosz, G. (2018). Experimental validation of connected automated vehicle design among human-driven vehicles. *Transportation research part C: emerging technologies*, 91, 335-352.
21. Bazzi, A., Campolo, C., Masini, B. M., Molinaro, A., Zanella, A. & Berthet, A. O. (2018). Enhancing Cooperative Driving in IEEE 802.11 Vehicular Networks through Full-Duplex Radios. *IEEE Trans. Wirel. Commun*, 17, 2402-2416.
22. Bian, K., Zhang, G. & Song, L. (2018). Toward Secure Crowd Sensing in Vehicle-to-Everything Networks. *IEEE Network*, 32(2), 126-131.
23. Gao, Y., Xu, X., Guan, Y. L. & Chong, P. H. J. (2018). V2X content distribution based on batched network coding with distributed scheduling. *IEEE Access*, 6, 59449-59461.
24. Martínez de Aragón, B., Alonso-Zarate, J. & Laya, A. (2018). How connectivity is transforming the automotive ecosystem. *Internet Technology Letters*, 1(1), e14.
25. Noor-A-Rahim, M., Ali, G. M. N., Nguyen, H. & Guan, Y. L. (2018). Performance Analysis of IEEE 802.11 p Safety Message Broadcast With and Without Relaying at Road Intersection. *IEEE Access*, 6, 23786-23799.
26. Inc., M. T. (2019). PIC16F877A. Recuperado el 18 de febrero de 2019, desde <https://www.microchip.com/PIC16F877A>
27. Technology, S. (2017). Sigfox Partnerships. Recuperado el 18 de febrero de 2019, desde <https://www.sigfox.com/en>
28. Thompson, A. W. (2018). Economic implications of lithium ion battery degradation for vehicle-to-grid (V2X) services. *Journal of Power Sources*, 396, 691-709.